

Town of Farmingdale Maine Solar Panel Permitting Policy

*all
Board
2/28/24
[Signature]*

Requirements prior to installation:

Building Permit- ground units are considered a structure, and roof or wall mounted units are fastened to the structural components of the building. Therefore, a building permit is required with the fee as detailed below.

Prior to issuing a building permit, a Maine Registered Architect or Maine Licensed Engineer needs to perform a Pre-installation Analysis of the building, and the solar system designed for the building, to ensure the structural integrity of the building will not be compromised. The Pre-installation Analysis must be stamped by the Registered Architect or Licensed Engineer who performed the analysis. Applications without the stamped Pre-installation Analysis will not be accepted.

Pre-installation Analysis:

The addition of roof mounted solar panels adds to the dead load on a roof. The dead load of the solar panels, as well as the snow and wind loading on the panels, are now imparted to the existing roof rafters at discrete points at the panel racking standoffs as compared to the existing uniform distribution of loads. This change in load path oftentimes exceeds a 5% increase when compared to the existing uniformly distributed loads. Calculations therefore must consider point loads due to snow, dead and wind loads at the point of attachment of the standoffs, in addition to other loads in the analysis.

Solar Panel Permit Fees:

\$50.00 plus \$0.15 per square foot of solar panel surface area.

Installation requirements:

1. Solar panel requirements of the National Electric Code (NFPA 70) adopted by the State of Maine at the time of the building permit application shall be enforced. If the solar panel system installation has not started within one year of the building permit application, the current National Electric Code (NFPA 70) adopted by the State of Maine at that time shall be enforced.
2. Firefighter Accessibility- Roof access points and pathways for firefighters are required. (See Figures 1 and 2 on Page 3 of this policy).
3. Access Points- Roof access points must be located at strong points of building construction, in areas that do not require ground ladders to be over windows or doors, or under overhead obstructions like trees, wires, or signs.
4. Limitations- Each PV array is limited to one hundred fifty (150) feet in either direction.
5. Separation- Multiple arrays must be separated by a thirty-six (36) inch wide clear access pathway.

Town of Farmingdale Maine Solar Panel Permitting Policy (continued)

6. Hip roof

- I. Panels and modules on hip roofs must be located to provide a thirty-six (36) inch wide clear access pathway from the eave to the ridge on all roof sections containing solar equipment, except on roof slopes of 2:12 or less.
 - II. Panels and modules on roofs with hips and valleys must not be located less than eighteen (18) inches from a hip or valley where solar equipment is to be placed on both sides of the hip or valley. Where panels or modules are only on one side of the hip or valley, they may be placed directly adjacent to the hip or valley, except on roof slopes of 2:12 or less.
7. Single ridge roof- Panels and modules on roofs with a single ridge must be located to provide a thirty-six (36) inch wide clear access pathway from the eave to the ridge on all roof sections containing solar equipment, except on roof slopes of 2:12 or less.
 8. Ridge clearance- Panels and modules must be a minimum of eighteen (18) inches from the ridge to allow fire department ventilation operations. Panels may be located up to the ridge when the fire chief determines ventilation operations will not be used, or when the fire chief approves alternate ventilation methods.

Post installation inspection:

1. The applicant shall notify the Town Code Enforcement Officer (CEO) when installation is complete.
2. The installation shall be inspected by the CEO, or designee, for conformance with this policy.
3. The Town Fire Chief, or designee(s), shall accompany the CEO on the inspection so they know how to approach the building in the event of a fire, and the location of roof pathways between panels.
4. Upon a passed inspection by the CEO, a Certificate of Solar Conformance will be issued to the applicant.

Town of Farmingdale Maine Solar Panel Permitting Policy (continued)

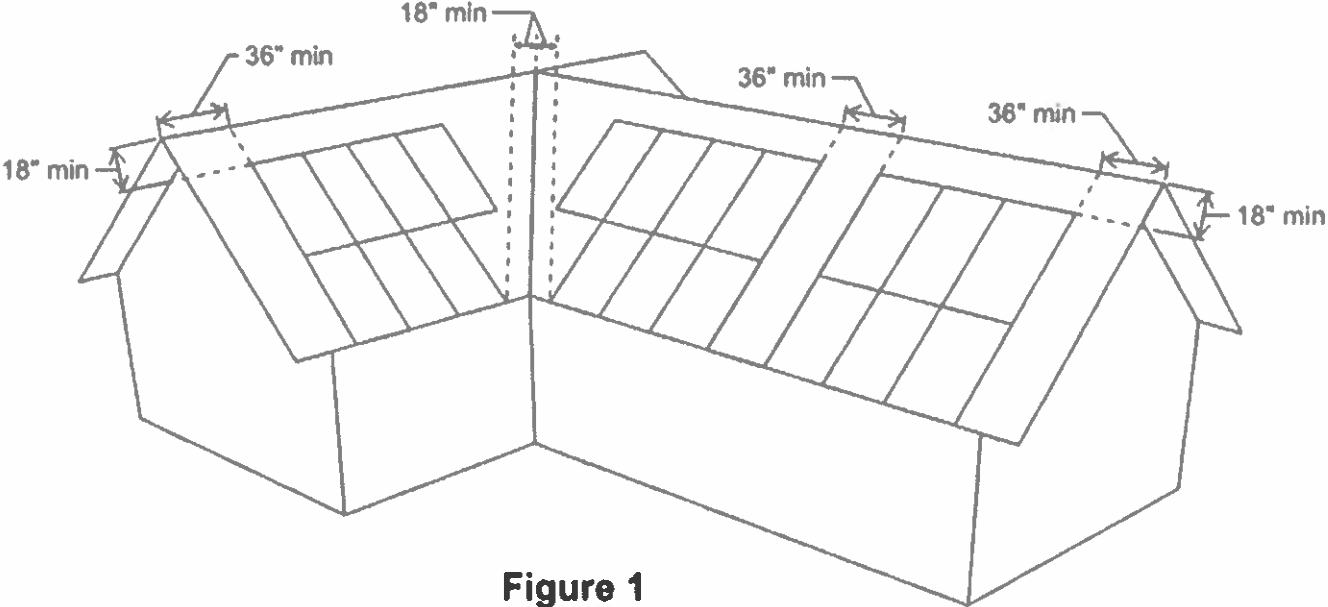

Figure 1

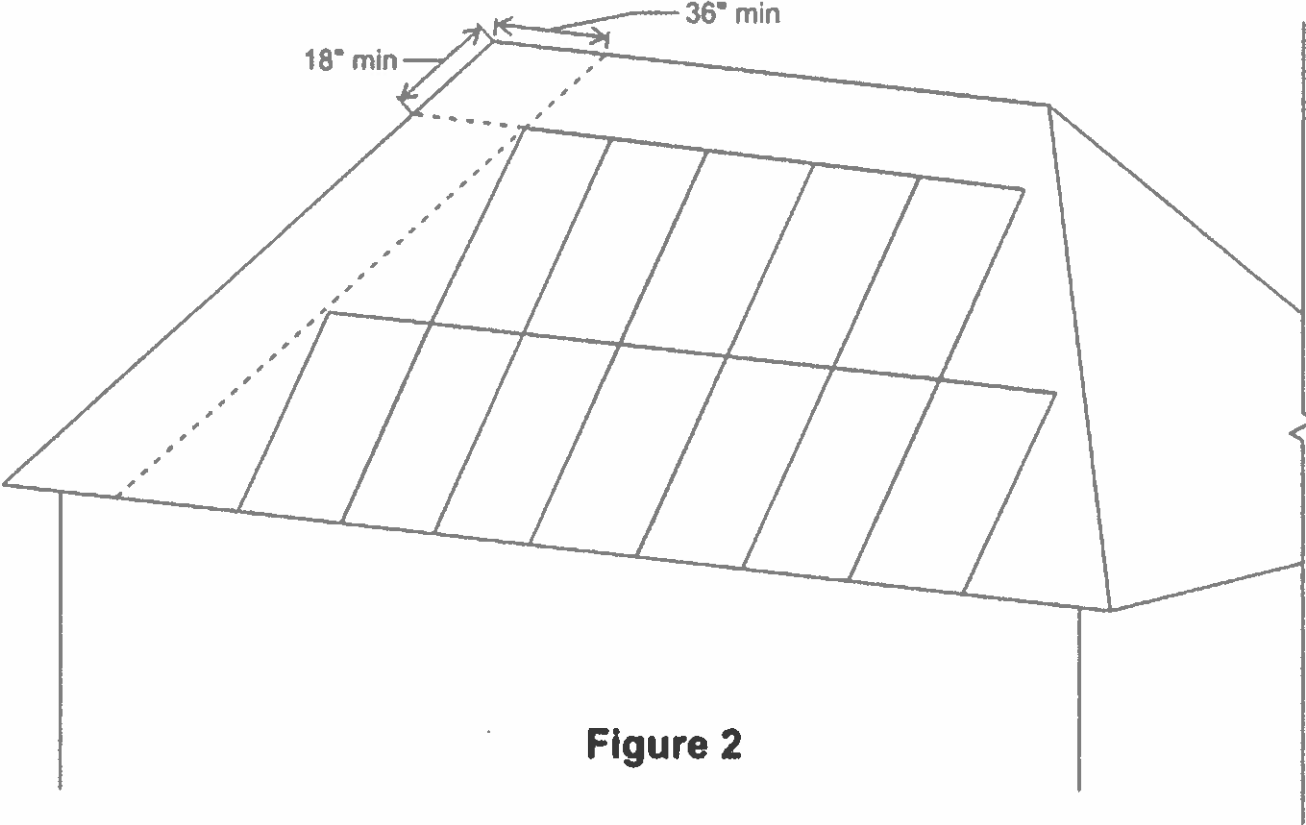

Figure 2